

IWAKI **Gas-Liquid Transfer Pump**

APN-085-W

Instruction Manual

 Read this manual before use of product

Thank you for selecting the IWAKI APN series gas-liquid transfer pump. This instruction manual deals with "Safety Instructions", "Outline", "Installation", "Operation" and "Maintenance" sections.

Please read through this instruction manual to ensure the optimum performance, safety and service of your pump.

Contents

| | |
|--|----------|
| Safety Instructions | 1 |
| <i>Outline</i> | |
| 1. Unpacking & Inspection | 3 |
| 2. Operating principle | 3 |
| 3. Identification code | 4 |
| 4. Specifications | 4 |
| 5. Outer dimension | 5 |
| 6. Performance curve | 5 |
| 7. Overview & Label | 6 |
| 8. Part names & Structure | 6 |
| <i>Installation</i> | |
| 1. Before installation | 8 |
| 2. Installation/Tubing/Electrical wiring | 10 |
| <i>Operation</i> | |
| 1. Before operation | 12 |
| 2. Pump operation | 13 |
| <i>Maintenance</i> | |
| 1. Troubleshooting | 15 |
| 2. Maintenance & Inspection | 15 |
| 3. Wear part replacement | 17 |



This instruction manual should be kept on hand by the end user for quick reference.

Contact us or your nearest dealer if you have any questions.



Important Instruction

For the Safe and Correct Handling of the Pump

- "Safety Instruction" section deals with important details about handling of the product. Before use, read this section carefully for the prevention of personnel injury or property damage.
- Observe the instructions accompanied with "WARNING" or "CAUTION" in this manual. These instructions are very important for protecting pump users from dangerous situations.
- The symbols on this instruction manual have the following meanings:

| | |
|--|---|
|  WARNING | Nonobservance or misapplication of the contents of "Warning" section could lead to a serious accident which may result in death. |
|  CAUTION | Nonobservance or misapplication of the contents of "Caution" section could lead to personal injury or property damage. |

Types of Symbols

| | |
|---|--|
|  | Indicates a prohibited action or procedure. Inside or near this circle, a concrete and practical image of the activity to be avoided is depicted. |
|  | Indicates an important action or procedure which must be performed or carried out without fail. Failure to follow the instructions herein can lead to malfunction or damage to the pump. |

For exportation

Technology related to the use of goods in this instruction manual falls in the category of technology contained in the Foreign Exchange Order Attachment, which includes complementary export control of technology. Please be reminded that export license, which is issued by the Ministry of Economy, Trade, and Industry could be required, when this is exported or provided to someone even in Japan.

Safety Instructions

WARNING

• Turn off power

Risk of electrical shock. Dismantling/assembling the pump unit without turning off power may cause an electrical shock. Before engaging in any maintenance or inspection work, be sure to turn off the pump and related devices.



Electrical shock

• For specified application only

The use of the pump in any application other than those clearly specified may result in injury or damage. Use the pump in a specified condition.



Prohibited

• No modification

Do not modify the pump. We are not responsible for any accidents or damage due to modification.



No remodeling

• Wear protective clothing

Always wear protective clothing such as a mask so as not to take in toxic fume during pipework or dismantlement.



Wear protectors

• Specified power only

Do not apply any power other than the specified one on the nameplate. Otherwise damage or fire may result.



Prohibited

CAUTION

• Restriction on operators

The pump should be handled by a qualified person with a full understanding.



Prohibited

• Ventilation

Poisoning may result when handling a toxic or odorous liquid. Keep good ventilation in a working area.



Caution

• Operating and Storage conditions

Do not install or store the pump in the following places where...

1. Ambient temperature exceeds 40°C or falls below 0°C.
2. Under a flammable/corrosive atmosphere.



Prohibited

• Countermeasure against efflux

Take protective measures against the accidental efflux caused by diaphragm breakage.



Caution

• Do not wet the pump

If a liquid spills over electric parts or wires, a fire or electrical shock may result. Install the pump in a place free from liquid spillage.



Prohibited

Safety Instructions

CAUTION

• Damaged pumps

Do not use any damaged pump. Using a damaged pump may lead to an electric leak or shock.



Prohibited

• Stop operation

Finding any abnormality, stop operation immediately and inspect/solve problems.



• Pump dismantlement

Dismantlement should be carried out within the descriptions in this instruction.



• Do not damage a power cable

Risk of fire or electrical shock. Do not scratch, modify, or pull a power cable. The cable can also be damaged when it is heated or loaded with a heavy thing.



Electrical shock

• Do not place the pump close to water

The pump is not dust-/water-proof construction. The use of the pump in a humid place or a place where the pump can get wet may result in electrical shock or short-circuit.



Prohibited

CAUTION

• Install an earth leakage breaker

Risk of electrical shock. Do not use the pump without an earth leakage breaker. Purchase separately.



Electrical shock

• Damaged power cable

Do not use any damaged power cable for the prevention of a fire or electrical shock. The cable is not replaceable, so that the whole pump unit needs to be replaced when the cable is damaged.



Electrical shock

• Pump disposal

Dispose of any used or damaged pump in accordance with local laws and regulations (Consult a licensed industrial waste products disposing company.).



• Earth connection

Always earth the pump in order to reduce the risk of electrical shock.



Grounding

Outline

Before use, check the specification, limitation and hazardous nature of the pump.

1. Unpacking & Inspection

On unpacking the product, check the following points. If you find any problems, contact your nearest distributor.

1. Check the information on the nameplate to see that the product is delivered as per order.
2. Check for transit damage, deformation, and loose bolts.

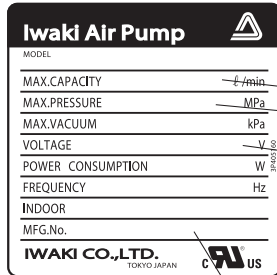

Flow rate
Discharge pressure
Power voltage
Manufacturing No.

2. Operating principle

The APN-085-W is a gas-liquid transfer pump with a small size diaphragm and special valves, and is designed for built-in application.

The rotary motion of the motor is converted via a connecting rod to the reciprocation of the diaphragm in the pump chamber, where the mixture of gas and liquid is transferred from the inlet to outlet.

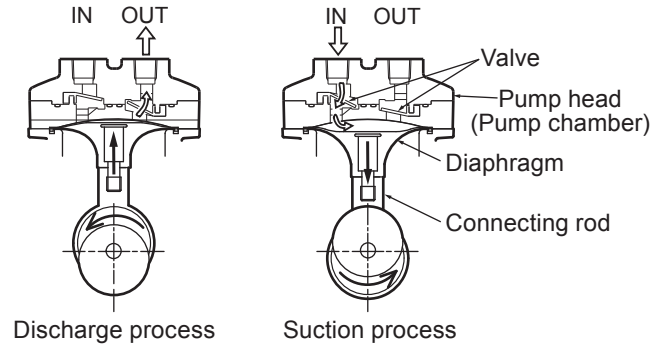

→ : Diaphragm reciprocation
⇒ : Flow direction

3. Identification code

APN - P 085 E X - E4 - W 02

a b c d e f g

a. Pump head

No code : Single

P : Twin parallel

b. Series name

c. Diaphragm materials

E : EPDM

V : FKM

d. Pump connection

X : Thread connection (Rc1/8)

e. Rated voltage

E4 : 220V/240VAC with a Cabtyre cable

f. Gas-liquid transfer type

g. Special specification

No code : Standard

01-99 : Special design

4. Specifications

■ Pump

50Hz, 220/240V

| Type | Max. air flow (L/min) | Max. discharge pressure (MPa) | Max. vacuum (kPa) | Motor | | | Conncetion Thread | Weight (kg) | Lowest starting temp. (°C) |
|-----------|-----------------------|-------------------------------|-------------------|----------------|------------|-------------------|-------------------|-------------|----------------------------|
| | | | | Power con. (W) | Output (W) | Rated current (A) | | | |
| APN-085E | 3 | 0.05 | 34.66 | 48 | 20 | 0.22 | Rc1/8 | 2.5 | 5 |
| APN-085V | | | 37.33 | | | | | | |
| APN-P085E | 5 | | 34.66 | | | | | | |
| APN-P085V | | | 37.33 | | | | | | |

NOTE1. Observe the maximum discharge pressure of 0.05MPa.

NOTE2. Allowable gas temperature range is 0-40°C.

NOTE3. Allowable liquid temperature range is 5-40°C.

NOTE4. Allowable ambient temperature range is 0-40°C.

Observe the lowest starting temperature at the start of operation.

NOTE5. Both the inlet and outlet of the pump are Rc1/8 female thread connections (JIS taper pipe thread).

■ Wet end material

| Parts | Model | V | E |
|------------|-------|-------|------|
| Pump head | | GFRPP | |
| Diaphragm | | FKM | EPDM |
| Valve | | | |
| Valve seat | | GFRPP | |
| Gasket | | FKM | EPDM |

GFRPP : Glass fiber reinforced polypropylene

FKM : Fluorine-contained rubber

EPDM : Ethylene propylene diene monomer

5. Outer dimension

■ APN-085-W (Single)

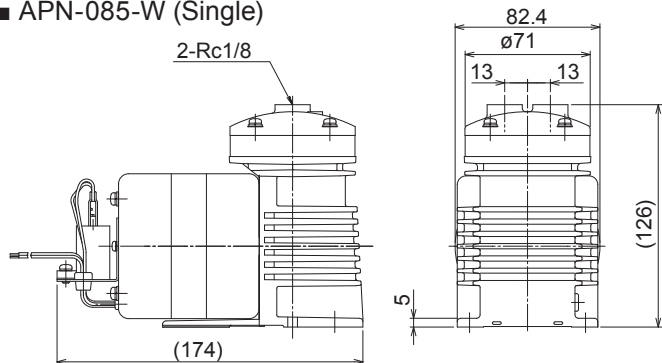

■ APN-P085-W (Twin parallel)

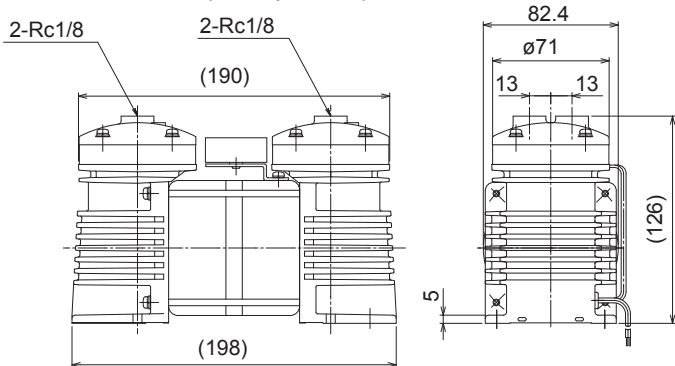

6. Performance curve

■ APN-085-W (Single)

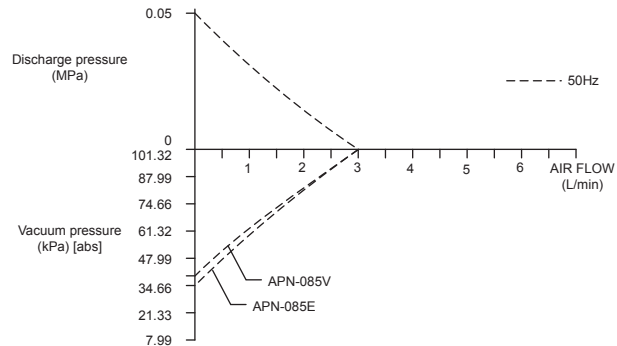

■ APN-P085-W (Twin parallel)

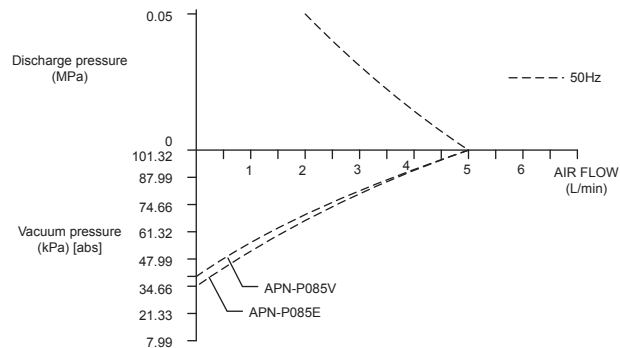

7. Overview & Label

The illustration below shows an APN-085-W single head type.

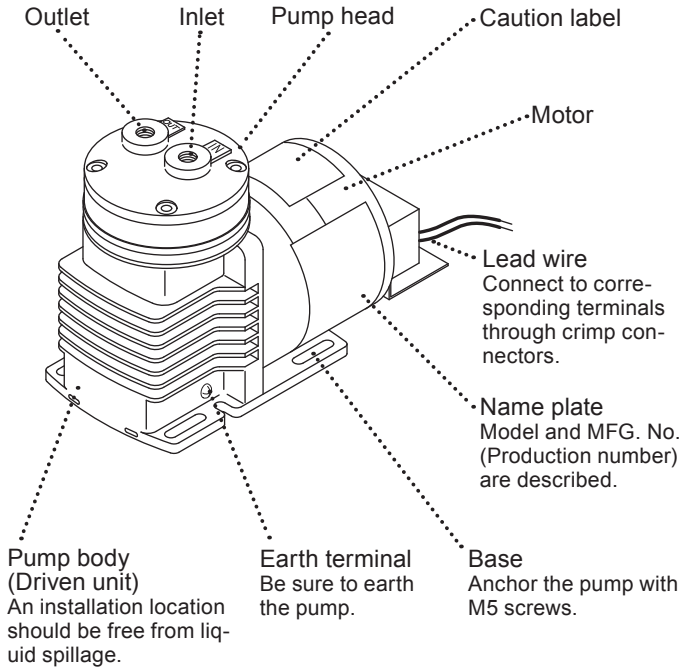

8. Part names & Structure

■ APN-085-W

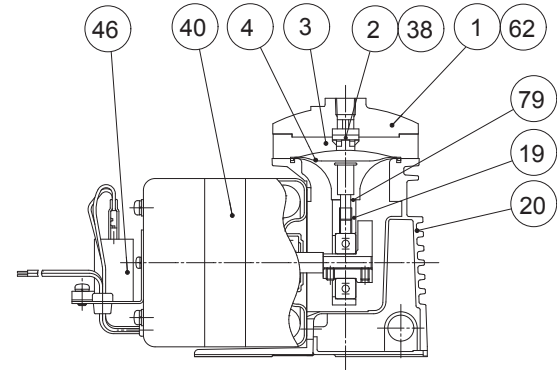

| No. | Part names | Q'ty |
|-----|---------------------|-------|
| 1 | Pump head | 1 |
| 2 | Valve | 2 |
| 3 | Valve seat | 1 |
| 4 | Diaphragm | 1 |
| 19 | Connecting rod unit | 1 set |

| No. | Part names | Q'ty |
|-----|--------------|------|
| 20 | Bracket | 1 |
| 40 | Motor | 1 |
| 46 | Capacitor | 1 |
| 62 | Small screw | 4 |
| 79 | Plate washer | 1 |
| 38 | Gasket | 2 |

■ APN-P085-W

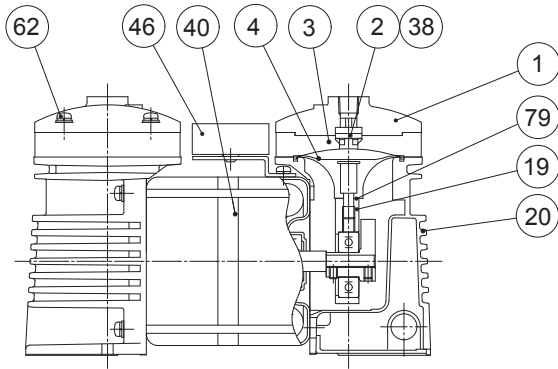

| No. | Part names | Q'ty |
|-----|---------------------|-------|
| 1 | Pump head | 2 |
| 2 | Valve | 4 |
| 3 | Valve seat | 2 |
| 4 | Diaphragm | 2 |
| 19 | Connecting rod unit | 2 set |

| No. | Part names | Q'ty |
|-----|--------------|------|
| 20 | Bracket | 2 |
| 40 | Motor | 1 |
| 46 | Capacitor | 1 |
| 62 | Small screw | 8 |
| 79 | Plate washer | 2 |
| 38 | Gasket | 4 |

Installation

1. Before Installation

Read through this instruction manual before use. Carry out installation work with a full understanding.



CAUTION

- **No fire**

Keep the pump away from flammable object.

- **Damaged pump**

Risk of electrical leakage and electrical shock.
Do not use a damaged pump.

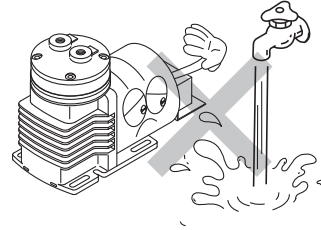

- **Instruction for use**

- Do not install the pump in a place where the pump can get wet.

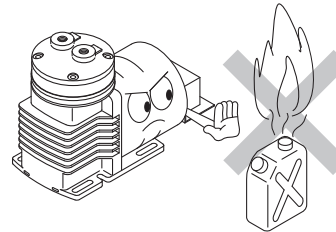

- Do not install the pump in a corrosive or flammable gas atmosphere. Keep good ventilation in a working area.

- Ambient temperature should not fall below 0°C or exceed 40°C. Observe the allowable gas temperature range of 0 and 40°C and liquid temperature range of 5 and 40°C.

Installation

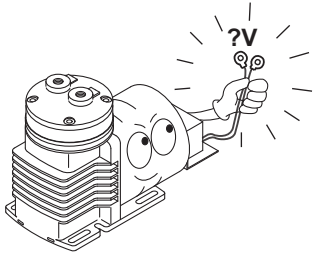

- Observe the rated voltage specified on the name plate. Applying any voltage than the rated one may result in failure.

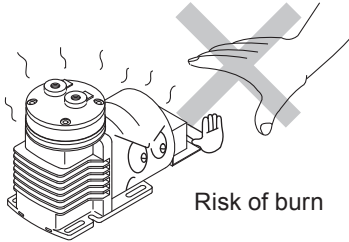

Risk of burn

- Surface temperature may rise high in operation but it dose not mean failure. Do not touch the pump body directly or place the objects which may be deformed by heat close to the pump.

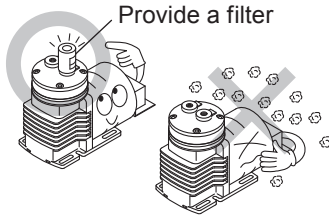

Provide a filter

- Do not use the pump in a dusty place. Be sure to provide the inlet with a filter to prevent foreign matters from getting into the pump. Otherwise, the pump performance may reduce or the lives of valves and diaphragm may remarkably shorten.

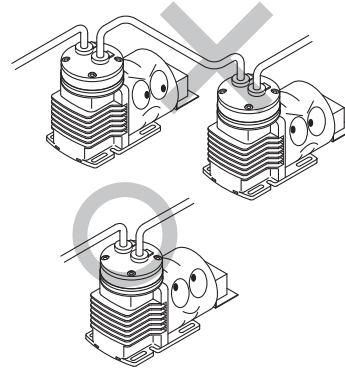

- Do not tube two or more pumps in series. It may prevent the motor from starting and lead to a burn out.

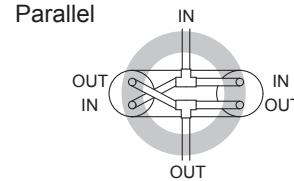

- The APN-P085-W is designed to be tubed in parallel only. Do not tube it in series.

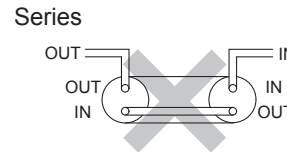

Installation

2. Installation/ Tubing/ Electrical wiring

WARNING

Stop working upon sensing danger or abnormality.

2.1 Installation

1. Do not expose the pump to direct sunlight, vibration and wind & rain.
2. Keep good ventilation. The pump should always be free from the possibility of getting wet.
3. Ambient temperature should not fall below 0°C or exceed 40°C. Observe the allowable maximum ambient humidity of 90%RH.
4. Install the pump in a clear and level place.
Select a convenient place for maintenance and inspection.

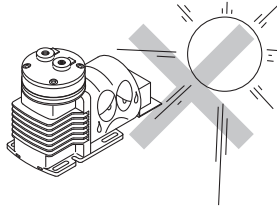

5. Pump fixation

Set the pump baseplate on a concrete foundation and fasten corrosion-resistant M5 screws tightly to prevent the pump from vibrating during operation.

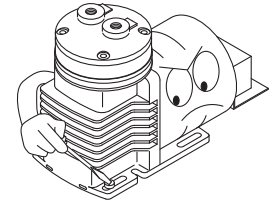

CAUTION

Do not install the pump on a wobbly pedestal.

2.2 Tubing

1. The short tubing with the minimum bends is optimal to reduce resistance.
2. Avoid sharp turns or bends.

CAUTION

Do not have tubing bent or pressed. Otherwise, the tube end may break.

3. Tubes and fittings

Provide tube fittings to the threaded inlet and outlet (Rc1/8) of the pump. Use chemically-resistant tubes or temperature-/pressure-resistant braided tubes as necessary. Cut the tube ends and have them flat before insertion.

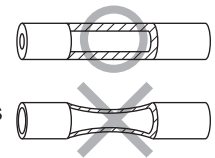

Installation

4. Tube size

For liquid transfer, a suction line bore should be $\varnothing 4\text{mm}$ or less. Otherwise, the motor is locked by overfeeding.

A discharge line bore should be $\varnothing 8\text{mm}$ or more.

CAUTION

Use of a large tube bears the risk of coming off, causing an air and a liquid leak.

5. Valve mounting

Install a ball valve in a suction line for adjusting an air/liquid flow or the degree of vacuum and in a discharge line for shutoff or the convenience of maintenance.

6. Tube and fitting connection

Wrap a sealing tape to the thread of tube fittings and screw them into the inlet and outlet of the pump. And then fit and slide tubes down onto the fittings as far as they will go.

NOTE: If suction line connection is imperfect, the pump sucks air and it prevents the pump from bringing out full performance.

2.3 Electrical wiring

Electrical wiring must be done by a qualified person who has a full knowledge of safety. We are not responsible for personal injury or property damage due to nonobservance of this warning. Contact us or your nearest distributor for wiring as necessary.

■ Before wiring

1. Confirm that power is disconnected before work.
2. Wiring work should be done in accordance with relevant electric work requirements. Use the recommended wiring accessories.
3. Observe the rated voltage specified on the name plate.
4. Earth the pump through the earth terminal.
5. Install the leakage breaker as necessary. When it has functioned, turn off power and check/solve problems to restore a normal state.

Operation

1. Before operation

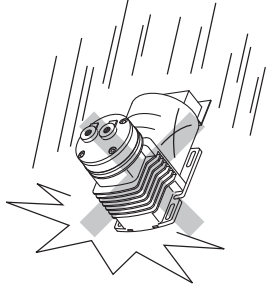

- Dropping or subjecting the pump to strong impact, failure may result. Handle the pump with care.

Suction pressure

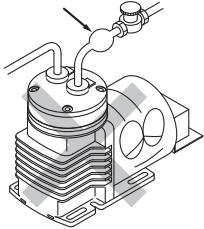

- The pump can not start with full discharge/suction pressure or full liquid. Remove pressure or liquid before operation.

No load operation

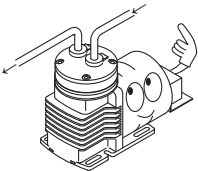

- After a long period of stoppage, pump performance at the beginning of operation becomes occasionally unstable. In this case, warm the pump up for 10 minutes with no discharge line pressure.

Suction valve

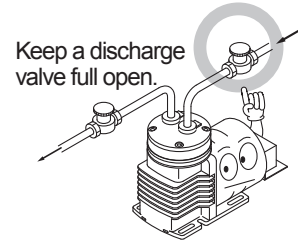

Keep a discharge valve full open.

- Always use a suction valve to adjust an air/liquid flow.

Suction valve

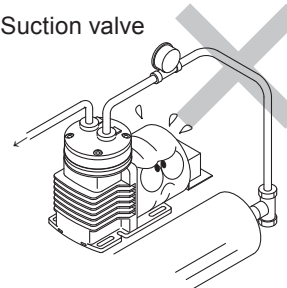

Do not apply suction line pressure

- If the compressed air or liquid (higher pressure than atmospheric pressure) is transferred to the pump, sharp deterioration to the lives of the valves, diaphragm and bearing may result. The suction line pressure should be equal to atmospheric pressure or vacuum pressure.

- Do not use solvents such as benzene, alcohol, thinner for maintenance or cleaning, otherwise a coat discolours or comes off.

Operation

2. Pump operation

■ Start-up

1. Before pump operation, check that each tube connection is secured.
 2. Check that a suction tube is connected to the inlet and a discharge tube is connected to the outlet.
- ⚠ CAUTION**
If a suction line and a discharge line are connected the other way around, pumping process is inverted.
3. Check that the pump is firmly fixed on a mounting position.

■ Operation

Operate the pump according to the following steps.

| No. | Procedure | Contents |
|-----|---------------------------------------|--|
| 1 | Check tubing, wiring and voltage. | <ul style="list-style-type: none"> ● Check installation, tubing and wiring are properly done and wiring system is fused. ● Check the spec label to see if power supply voltage is correct. |
| 2 | Open valves. | <ul style="list-style-type: none"> ● Fully open both discharge and suction lines. |
| 3 | Supply power to the pump. | <ul style="list-style-type: none"> ● After checking the items 1 and 2. Turn on power and start the pump. ● Smooth starting may not be obtained when ambient temperature is 10°C or below. In this case, run the pump with no discharge line pressure for a few minutes to warm it up. ● Smooth starting may not be obtained when the pump chamber is filled with liquid. Get rid off liquid before operation. |
| 4 | Adjust air flow. | <ul style="list-style-type: none"> ● After the pump has reached a specified stroke rate, initiate full scale operation. ● Always adjust an air flow by a suction valve. |
| 5 | Points to be checked during operation | <ul style="list-style-type: none"> ● After starting, check a pressure gauge to see if suction and discharge line pressure are correct and an air flow meter to see if the specified air flow is obtained. ● Keep a suction line pressure at or below atmospheric pressure. ● In case electric power has failed while the pump is running, switch off main power. Otherwise, the motor may not restart or may burn out depending on a line pressure at the time of power recovery. |

Operation

■ Stop and Storage

Before a long period of stoppage (1 week or more)...

- Release pressure and turn off main power.
- Make sure both supply air and gas are stopped.

Before resuming operation...

- Operation may occasionally be upset in the beginning. In this case warm up the pump under no load operation in advance.
- Follow the "■ Operation" table to resume operation.

Maintenance

1. Trouble shooting

Turn off power on sensing danger and check the following. In case trouble can not be solved, contact us or your nearest distributor.

| Phenomenon | | | | | Measures |
|--|-----------------------|-----------------------|-------------------------------------|-----------------------|--------------------------------------|
| Causes | Pump does not run. | Pump stops running. | Poor air flow or discharge pressure | Pump makes noise. | |
| No power distribution | <input type="radio"/> | <input type="radio"/> | <input type="radio"/> | <input type="radio"/> | Check wiring. |
| Motor trouble (disconnection or capacitor failure) | <input type="radio"/> | <input type="radio"/> | <input type="radio"/> | <input type="radio"/> | Replace the motor.* |
| Wrong tubing or poor connection | <input type="radio"/> | <input type="radio"/> | <input type="radio"/> | <input type="radio"/> | Check and fix tubing. |
| Pump head mounting screws are loose. | <input type="radio"/> | <input type="radio"/> | <input type="radio"/> | <input type="radio"/> | Tighten the screws. |
| Diaphragm insertion is loose. | <input type="radio"/> | <input type="radio"/> | <input type="radio"/> | <input type="radio"/> | Tighten diaphragm. |
| Diaphragm is damaged. | <input type="radio"/> | <input type="radio"/> | <input type="radio"/> | <input type="radio"/> | Replace diaphragm. |
| Filter is clogged. | <input type="radio"/> | <input type="radio"/> | <input type="radio"/> | <input type="radio"/> | Remove foreign matters. |
| Valves are worn. | <input type="radio"/> | <input type="radio"/> | <input type="radio"/> | <input type="radio"/> | Replace valves. |
| Motor-Bracket fixing screws are loose. | <input type="radio"/> | <input type="radio"/> | <input type="radio"/> | <input type="radio"/> | Secure them. |
| Eccentric shaft has worn. | <input type="radio"/> | <input type="radio"/> | <input type="radio"/> | <input type="radio"/> | Replace the connecting rod.* |
| Connecting rod bearing has worn. | <input type="radio"/> | <input type="radio"/> | <input type="radio"/> | <input type="radio"/> | Replace the connecting rod.* |
| Motor bearing has worn. | <input type="radio"/> | <input type="radio"/> | <input type="radio"/> | <input type="radio"/> | Replace the motor.* |
| Voltage reduction | <input type="radio"/> | <input type="radio"/> | <input type="radio"/> | <input type="radio"/> | Increase voltage to the rated level. |
| Higher suction pressure than atmospheric | <input type="radio"/> | <input type="radio"/> | <input type="radio"/> | <input type="radio"/> | Reduce suction pressure. |
| Condensation in the pump head | <input type="radio"/> | <input type="radio"/> | <input type="radio"/> | <input type="radio"/> | Dry up the pump. |

Contact us for the measures marked with *.

2. Maintenance & Inspection

Handling of the pump, maintenance and inspection should be carried out within this instruction manual. Do not handle the pump beyond the descriptions in this manual. We are not responsible for personal injury or property damage due to nonobservance of this warning. Contact us or your nearest distributor as necessary.

■ Daily inspection

Pay attention to the following items during operation. Stop operation on sensing danger and solve problems on the trouble shooting section. If pump performance has remarkably reduced, replace wear parts.

| No. | Check that... | Measure |
|-----|---|---|
| 1 | pump operation is normal. | <ul style="list-style-type: none"> • Apply correct voltage and amperage. • Adjust discharge/suction pressure. |
| 2 | there is no noise or vibration problem. | <ul style="list-style-type: none"> • Unusual noise/vibration may occur when pump operation is not normal. |
| 3 | there is no air leak or air ingress from pump parts and tubing connections. | <ul style="list-style-type: none"> • Retighten connections. |

Maintenance

■ Wear parts

If pump performance has remarkably reduced, replace diaphragms and valves with new ones. Wear part duration varies with the pressure, temperature and characteristics of gas/liquid. The estimated life below is calculated based on continuous operation with clean water in a room temperature range of 0-40°C.

| Application | Load range | Estimated life | | |
|-----------------|------------|----------------|-----------|--------|
| | | Valve | Diaphragm | Gasket |
| Gas transfer | All range | 8000hr | 8000hr | 8000hr |
| Liquid transfer | No load | 4000hr | 4000hr | 4000hr |

*The above lives are reference values and not warranted.

■ Cleaning

Turn off power and wait until the pump has cooled down. Then clean off the surface of the pump with a wet cloth. Use a neutral detergent for greasy dirt as necessary and dry it with a dry cloth.

Check the pump surface has dried up before operation.

CAUTION

Risk of electrical shock. Do not wet electric parts or wiring.

■ Storage

Protect the pump from dust during storage.

Do not store the pump in the following places where...

- Ambient temperature falls below 0°C or exceeds 40°C.
- Under a flammable or corrosive atmosphere.
- Under heavy dust or high humidity.
- Under direct sunlight or wind & rain.
- Under vibration.

Maintenance

3. Wear part replacement

For a long period of operation wear parts need to be replaced periodically.

CAUTION

- **Turn off power before work**

Risk of electrical shock. Be sure to turn off power to stop the pump and related devices before work.

- **Do not touch the pump or pipe with bare hands**

Risk of burning. The surface temperature of the pump or pipe gets high in or right after operation.

- **Wear protective clothing**

Always wear protective clothing such as a mask so as not to take in toxic fume during pipework or dismantlement.

See page 6 "8. Part names & Structure" as necessary.

■ Diaphragm replacement

1. Unscrew the pump head fixing screws and take out the pump head, valves, gaskets and valve seat.
2. Turn the diaphragm anti-clockwise so as to detach it from the rod.
3. Mount a new diaphragm into the rod and fasten as far as it will rotate.
4. Push down the diaphragm until it bottoms out and then reassemble and secure the above parts onto the bracket with the screws by 1.37N•m.

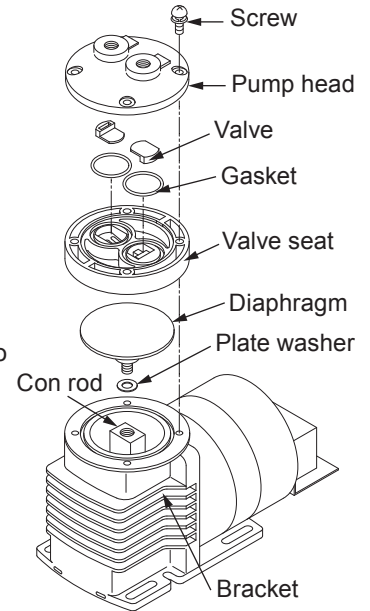

Maintenance

■ Valve & Gasket replacement

1. Unscrew the pump head fixing screws and dismantle the pump head unit.

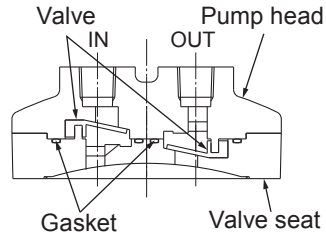

2. Replace old valves and gaskets with new ones and then reassemble the pump head unit.

3. Supply air into the pump head unit through the inlet and check the air is discharged through the outlet.

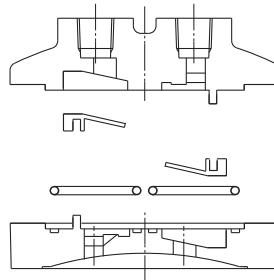

4. Push down the diaphragm until it bottoms out and then secure the unit onto the bracket with the screws by $1.37\text{N}\cdot\text{m}$.

NOTE1. For the APN-P085 twin parallel type, finish either pump head first and then start with the other.

NOTE2. Do not loosen the motor-bracket fixing screws during maintenance work.

NOTE3. Contact your nearest distributor for the replacement of the connecting rod and the motor.









IWAKI CO.,LTD. 6-6 Kanda-Sudacho 2-chome Chiyoda-ku Tokyo 101-8558 Japan
 TEL:(81)3 3254 2935 FAX:3 3252 8892(<http://www.iwakupumps.jp>)

()Country codes

| | | | | | | | |
|------------------|---|-----------------------|-------------------|--------------------|---|----------------------|---------------------|
| Australia | IWAKI Pumps Australia Pty. Ltd. | TEL:(61)2 9899 2411 | FAX:2 9899 2421 | Italy | IWAKI Italia S.R.L. | TEL:(39)0444 371115 | FAX:0444 335350 |
| Austria | IWAKI (Austria) GmbH | TEL:(43)2236 33469 | FAX:2236 33469 | Korea | IWAKI Korea Co.,Ltd. | TEL:(82)2 2630 4800 | FAX:2 2630 4801 |
| Belgium | IWAKI Belgium n.v. | TEL:(32)1367 0200 | FAX:1367 2030 | Malaysia | IWAKIm Sdn. Bhd. | TEL:(60)3 7803 8807 | FAX:3 7803 4800 |
| China | IWAKI Pumps (Shanghai) Co., Ltd. | TEL:(86)21 6272 7502 | FAX:21 6272 6929 | Norway | IWAKI Norge AS | TEL:(47)66 81 1660 | FAX:66 81 1661 |
| China | IWAKI Pumps (Guandong) Co., Ltd. | TEL:(86)750 3866228 | FAX:750 3866278 | Singapore | IWAKI Singapore Pte. Ltd. | TEL:(65)6316 2028 | FAX:6316 3221 |
| China | GFTZ IWAKI Engineering & Trading (Guangzhou) | TEL:(86)20 8435 0603 | FAX:20 8435 9181 | Spain | IWAKI Iberica Pumps, S.A. | TEL:(34)943 630030 | FAX:943 628799 |
| China | GFTZ IWAKI Engineering & Trading (Beijing) | TEL:(86)10 6442 7713 | FAX:10 6442 7712 | Sweden | IWAKI Sverige AB | TEL:(46)8 511 72900 | FAX:8 511 72922 |
| Denmark | IWAKI Nordic A/S | TEL:(45)48 24 2345 | FAX:48 24 2346 | Switzerland | IWAKI (Schweiz) AG | TEL:(41)26 674 9300 | FAX:26 674 9302 |
| Finland | IWAKI Suomi Oy | TEL:(358)9 2745810 | FAX:9 2742715 | Taiwan | IWAKI Pumps Taiwan Co., Ltd. | TEL:(886)2 8227 6900 | FAX:2 8227 6818 |
| France | IWAKI France S.A. | TEL:(33)1 69 63 33 70 | FAX:1 64 49 92 73 | Taiwan | IWAKI Pumps Taiwan (Hsin-chu) Co.,Ltd. | TEL:(886)3 573 5797 | FAX:(886)3 573 5798 |
| Germany | IWAKI EUROPE GmbH | TEL:(49)2154 92540 | FAX:2154 9254 48 | Thailand | IWAKI (Thailand) Co.,Ltd. | TEL:(66)2 322 2471 | FAX:2 322 2477 |
| Holland | IWAKI EUROPE NL Branch | TEL:(31)547 293 160 | FAX:547 292 332 | U.K. | IWAKI Pumps (UK) LTD. | TEL:(44)1743 231363 | FAX:1743 366507 |
| Hong Kong | IWAKI Pumps Co., Ltd. | TEL:(852)2 607 1168 | FAX:2 607 1000 | U.S.A. | IWAKI AMERICA Inc. | TEL:(1)508 429 1440 | FAX:508 429 1386 |
| Indonesia | IWAKI Singapore (Indonesia Branch) | TEL:(62)21 690 6606 | FAX:21 690 6612 | Vietnam | IWAKI pumps Vietnam Co.,Ltd. | TEL:(84)613 933456 | FAX:613 933399 |