

IWAKI

Gas-Liquid Transfer Pump

APN-30/-60 GD3-W

Instruction Manual

 Read this manual before use of product

Thank you for selecting an IWAKI APN-30/-60 GD3-W gas-liquid transfer pump (BLDC motor). This instruction manual deals with "Safety Instructions", "Outline", "Installation", "Operation" and "Maintenance" sections.

Please read through this instruction manual to ensure the optimum performance, safety and service of your pump.

Contents

| | |
|--|----------|
| Safety Instructions | 1 |
| <i>Outline</i> | |
| 1. Unpacking & Inspection | 3 |
| 2. Operating principle | 3 |
| 3. Identification code | 3 |
| 4. Specifications | 4 |
| 5. Outer dimension | 5 |
| 6. Performance curve | 6 |
| 7. Overview & Label | 6 |
| 8. Part names & Structure | 7 |
| <i>Installation</i> | |
| 1. Before installation | 8 |
| 2. Installation/Tubing/Electrical wiring | 10 |
| <i>Operation</i> | |
| 1. Before operation | 12 |
| 2. Pump operation | 13 |
| <i>Maintenance</i> | |
| 1. Troubleshooting | 15 |
| 2. Maintenance & Inspection | 15 |



This instruction manual should be kept on hand by the end user for quick reference.

Contact us or your nearest dealer if you have any questions.



Important Instruction

For the Safe and Correct Handling of the Pump

- "Safety Instruction" section deals with important details about handling of the product. Before use, read this section carefully for the prevention of personnel injury or property damage.
- Observe the instructions accompanied with "WARNING" or "CAUTION" in this manual. These instructions are very important for protecting pump users from dangerous situations.
- The symbols on this instruction manual have the following meanings:

| | |
|--|---|
|  WARNING | Nonobservance or misapplication of the contents of "Warning" section could lead to a serious accident which may result in death. |
|  CAUTION | Nonobservance or misapplication of the contents of "Caution" section could lead to personal injury or property damage. |

Types of Symbols

| | |
|---|--|
|  | Indicates a prohibited action or procedure. Inside or near this circle, a concrete and practical image of the activity to be avoided is depicted. |
|  | Indicates an important action or procedure which must be performed or carried out without fail. Failure to follow the instructions herein can lead to malfunction or damage to the pump. |

For exportation

Technology related to the use of goods in this instruction manual falls in the category of technology contained in the Foreign Exchange Order Attachment, which includes complementary export control of technology. Please be reminded that export license, which is issued by the Ministry of Economy, Trade, and Industry could be required, when this is exported or provided to someone even in Japan.

Safety Instructions

WARNING

• Turn off power

Risk of electrical shock. Dismantling/assembling the pump unit without turning off power may cause an electrical shock. Before engaging in any maintenance or inspection work, be sure to turn off the pump and related devices.



Electrical shock

• For specified application only

The use of the pump in any application other than those clearly specified may result in injury or damage. Use the pump in a specified condition.



Prohibited

• No modification

Do not modify the pump. We are not responsible for any accidents or damage due to modification.



No remodeling

• Wear protective clothing

Always wear protective clothing such as safety goggles and protective gloves during pipework or dismantlement.



Wear protectors

• Specified power only

Do not apply any power other than the specified one on the nameplate. Otherwise damage or fire may result.



Prohibited

CAUTION

• Restriction on operators

The pump should be handled by a qualified person with a full understanding.



Prohibited

• Ventilation

Poisoning may result when handling a toxic or odorous liquid. Keep good ventilation in a working area.



Caution

• Operating and Storage conditions

Do not install or store the pump in the following places where...

1. Ambient temperature exceeds 40°C or falls below 0°C.
2. Under a flammable/corrosive atmosphere.



Prohibited

• Countermeasure against efflux

Take protective measures against the accidental efflux caused by diaphragm breakage.



Caution

• Do not wet the pump

If a liquid spills over electric parts or wires, a fire or electrical shock may result. Install the pump in a place free from liquid spillage.



Prohibited

Safety Instructions

CAUTION

• Damaged pumps

Do not use any damaged pump. Using a damaged pump may lead to an electric leak or shock.



Prohibited

• Stop operation

Finding any abnormality, stop operation immediately and inspect/solve problems.



• Do not damage a power cable

Risk of fire or electrical shock. Do not scratch, modify, or pull a power cable. The cable can also be damaged when it is heated or loaded with a heavy thing.



Electrical shock

• Do not place the pump close to water

The pump is not dust-/water-proof construction. The use of the pump in a humid place or a place where the pump can get wet may result in electrical shock or short-circuit.



Prohibited

CAUTION

• Damaged power cable

Do not use any damaged power cable for the prevention of a fire or electrical shock. The cable is not replaceable, so that the whole pump unit needs to be replaced when the cable is damaged.



Electrical shock

• Pump disposal

Dispose of any used or damaged pump in accordance with local laws and regulations (Consult a licensed industrial waste products disposing company.).



Outline

Before use, check the specification, limitation and hazardous nature of the pump.

1. Unpacking & Inspection

On unpacking the product, check the following points. If you find any problems, contact your nearest distributor.

1. Check the information on the nameplate to see that the product is delivered as per order.
2. Check for transit damage, deformation, and loose bolts.

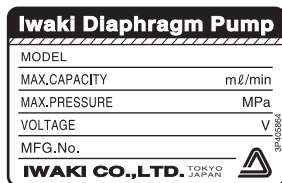

2. Operating principle

The APN-30/-60 GD3-W is a gas-liquid transfer pump with a small size diaphragm.

The rotary motion of the motor is converted via a connecting rod to the reciprocation of the diaphragm in the pump chamber, where the mixture of gas and liquid is transferred from the inlet to outlet.

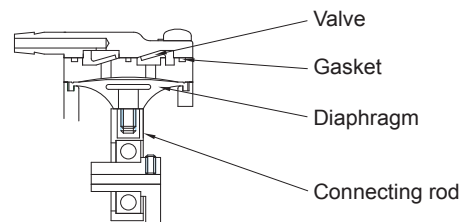

3. Identification code

APN-30 G D3 - W 02

a b c d e

- | | |
|-----------------------------|-------------------|
| a. Series name | 30 : APN-30 type |
| | 60 : APN-60 type |
| b. Bracket type | With a base plate |
| c. Rated voltage | D3 : 24V BLDC |
| d. Gas-liquid transfer type | |
| e. Special specification | |

Outline

4. Specifications

■ Pump

| Type | Air flow rate (ml/min) | Maximum discharge pressure (MPa) | Maximum vacuum (kPa) | Liquid flow rate (ml/min) | Motor | | Connection bore | Mass (g) | Lowest starting temperature (°C) |
|--------|------------------------|----------------------------------|----------------------|---------------------------|--------------|-------------|-----------------|----------|----------------------------------|
| | | | | | Amperage (A) | Voltage (V) | Hose | | |
| APN-30 | 1000 | 0.08 | 47.99 | 300 | 0.6 | 24DC | ø5.5 | 240 | 5 |
| APN-60 | | | | 600 | | | | | |

NOTE 1. Discharge pressure should not exceed the limit shown above.

2. Gas temperature should be between 5-40deg.C.

Liquid temperature should be between 10-40deg.C.

3. Ambient temperature should be between 5-40deg.C.

Wet end material

| Parts | Material | FKM type |
|------------|----------|----------|
| Pump head | GFRPP | |
| Diaphragm | FKM | |
| Valve | FKM | |
| Valve seat | GFRPP | |
| Gasket | FKM | |

5. Outer dimension

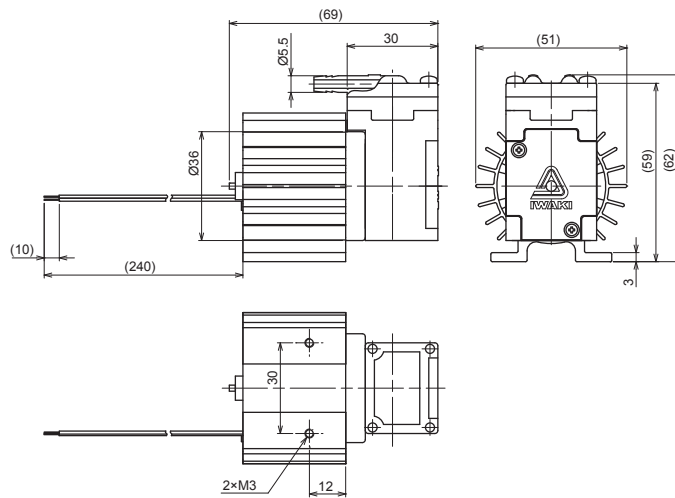

Outline

6. Performance curve (gas transfer)

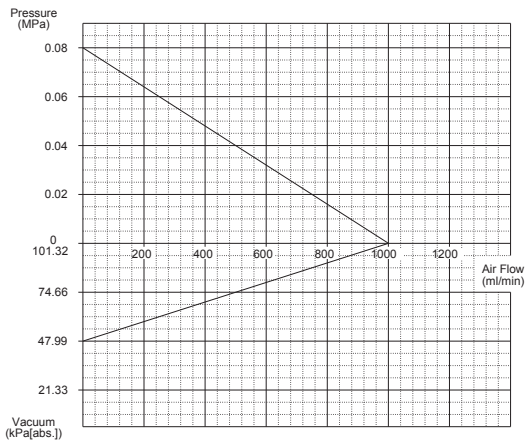

7. Overview & Label

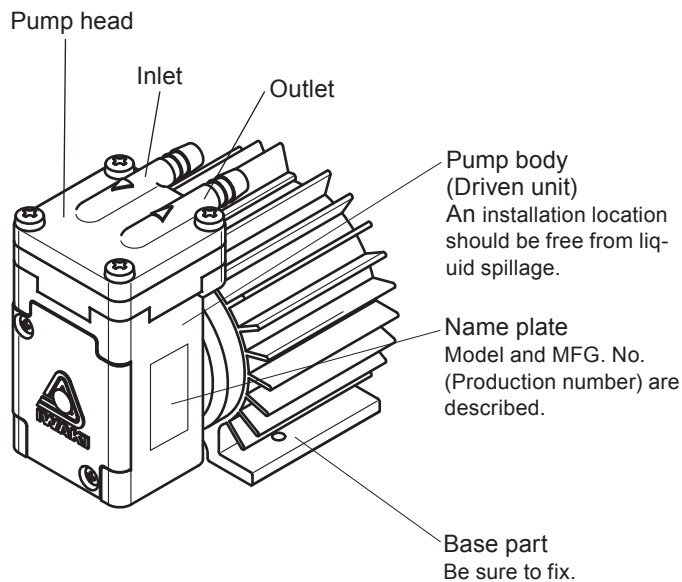

8. Part names & Structure

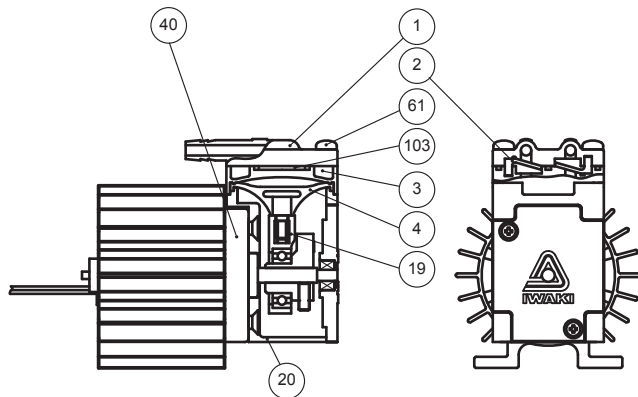

| Code | Name | Q'ty |
|------|---------------------|-------|
| 1 | Pump head | 1 |
| 2 | Valve | 2 |
| 3 | Valve seat | 1 |
| 4 | Diaphragm | 1 |
| 19 | Connecting rod unit | 1 set |

| Code | Name | Q'ty |
|------|---------|------|
| 20 | Bracket | 1 |
| 40 | Motor | 1 |
| 61 | Screw | 4 |
| 103 | Gasket | 1 |

Installation

1. Before Installation

Read through this instruction manual before use. Carry out installation work with a full understanding.

CAUTION

- No fire
Keep the pump away from flammable object.
- Damaged pump
Risk of electrical leakage and electrical shock.
Do not use a damaged pump.

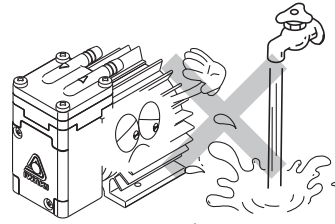

- Instruction for use
- Do not install the pump in a place where the pump can get wet.

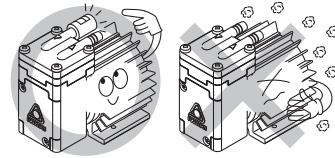

- For gas transfer, do not use the pump in a dusty place. Be sure to provide the inlet with a filter to prevent foreign matters from getting into the pump. Otherwise, the pump performance may reduce or the lives of the valve and diaphragm may remarkably shorten.

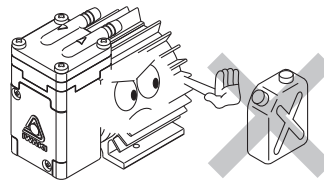

- Do not install the pump in a corrosive or flammable gas atmosphere. Keep good ventilation in a working area. The allowable ambient and air temperature is between 5 and 40°C. Liquid temperature should be between 10 and 40°C.

Installation

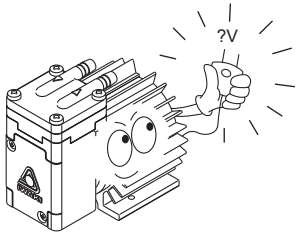

- Observe the rated voltage specified on the name plate. Applying any voltage than the rated one may result in failure.

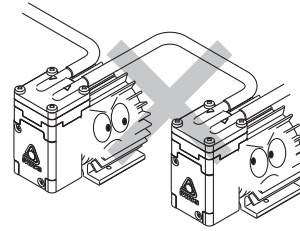

- Do not tube two or more pumps in series. It may prevent the motor from starting and lead to a burn out.

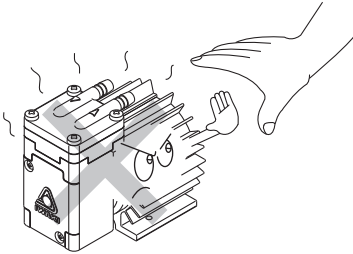

- Surface temperature may rise high in operation but it dose not mean failure. Do not touch the pump body directly or place the objects which may be deformed by heat close to the pump.

Installation

2. Installation/ Tubing/ Electrical wiring

WARNING

Stop working upon sensing danger or abnormality.

2.1 Installation

1. Installation location

- The ambient temperature in an installation location should be between 5 and 40°C. Relative humidity should be 90% or below. Select a convenient place for maintenance and inspection.
- Install the pump in a clear and level place.
- Keep good ventilation. The pump should always be free from liquid spillage.

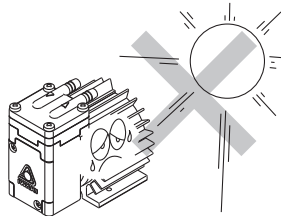

2. Pump fixation

Secure the pump by fixing the base.

CAUTION

Do not install the pump on a wobbly pedestal.

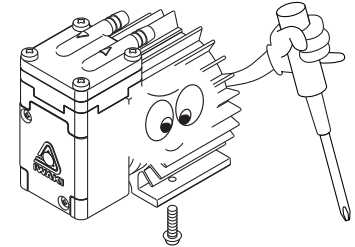

3. Tube preparation

Cut the tube ends and have them flat before insertion.

2.2 Tubing

1. The short tubing with the minimum bends is optimal to reduce resistance.
2. Vinyl tubes should be resistant to the pumping pressure.

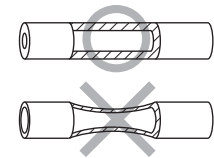

CAUTION

Do not have tubing bent or pressed. Otherwise, the tube end may break.

Installation

3. For liquid transfer, a suction line bore should be $\varnothing 4$ mm or less. Otherwise, the motor is locked by overfeeding. A discharge line bore should also be $\varnothing 4$ mm or less.
4. Tube size
Select proper tube size with pressure resistance, otherwise air/liquid leaks and failure may result. Use of the braided tube is recommended.
5. Valve mounting
Install a valve in the suction line between the pump and a supply tank for adjusting an air/liquid flow and the degree of vacuum.
6. Tube connection
Push the tubes into the inlet and outlet as far as it will go.
7. Tube should be thick enough. The use of a thin and light tube may reduce suction force and an air flow.
8. Use tube bands to ensure firm connections.

NOTE: If suction line connection is imperfect, the pump sucks air and it prevents the pump from bringing out full performance.

2.3 Electrical wiring

Electrical wiring must be done by a qualified person who has a full knowledge of safety. We are not responsible for personal injury or property damage due to nonobservance of this warning. Contact us or your nearest distributor for wiring as necessary.

■ Before wiring

1. Confirm that power is disconnected before work.
2. Wiring work should be done in accordance with relevant electric work requirements. Use the recommended wiring accessories.
3. Observe the rated voltage specified on the name plate.
4. Install the leakage breaker as necessary. When it has functioned, turn off power and check/solve problems to restore a normal state.

● Wiring

1. DC type pumps are specifically for DC power voltage.
2. For wire colour, red is $+$ and black is $-$. Ensure correct DC power connections.
3. Provide a fuse for safety.

NOTE: The motor could be damaged in case the motor is overheated by any possibility. Be sure to equip a fuse.

Operation

1. Before operation

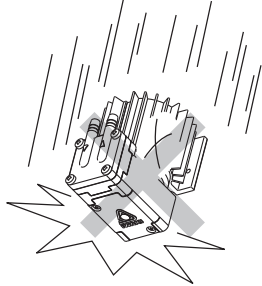

- Dropping or subjecting the pump to strong impact, failure may result. Handle the pump with care.

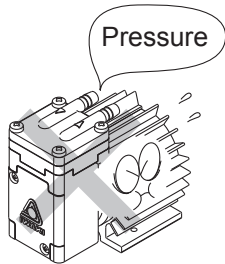

- The pump can not start with full discharge/suction pressure or full liquid. Remove pressure or liquid before operation. After a long period of stoppage, pump performance at the beginning of operation becomes occasionally unstable. In this case, warm the pump up by running pump up by running pump dry for about ten minutes.

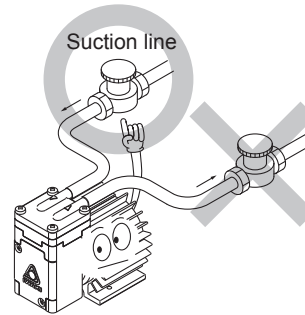

- Always use a suction valve to adjust an air/liquid flow.

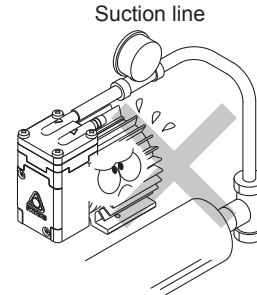

- If the compressed air or liquid (higher pressure than atmospheric pressure) is transferred to the pump, sharp deterioration to the lives of the valves, diaphragm and bearing may result. The suction line pressure should be equal to atmospheric pressure or vacuum pressure.
- Do not use solvents such as benzene, alcohol, thinner for maintenance or cleaning, otherwise a coat discolours or comes off.

Operation

2. Pump operation

■ Start-up

1. Before pump operation, check that each tube and the outlet & inlet are firmly connected.
 2. Check that a suction line is connected to the inlet and a discharge line is connected to the outlet.
- ⚠ CAUTION**
If a suction line and a discharge line are connected the other way around, pumping process is inverted.
3. Check that the pump is firmly fixed on a mounting position.
 4. When applying the larger voltage than rated one, or when the motor is locked, the motor heats up and the coil may break. Do not apply an unspecified voltage or lock the motor.

■ Operation

Operate the pump according to the following steps.

| No. | Procedure | Contents |
|-----|---------------------------------------|--|
| 1 | Check tubing, wiring and voltage. | <ul style="list-style-type: none"> ● Check installation, tubing and wiring are properly done and wiring system is fused. ● Check the spec label to see if power supply voltage is correct. |
| 2 | Open valves. | <ul style="list-style-type: none"> ● Fully open both discharge and suction lines. |
| 3 | Supply power to the pump. | <ul style="list-style-type: none"> ● After checking the items 1 and 2. Turn on power and start the pump. ● Smooth starting may not be obtained when ambient temperature is 10°C or below. In this case, run the pump with no discharge line pressure for a few minutes to warm it up. ● Smooth starting may not be obtained when the pump chamber is filled with liquid. Get rid off liquid before operation. |
| 4 | Adjust air flow. | <ul style="list-style-type: none"> ● After the pump has reached a specified stroke rate, initiate full scale operation. ● Always adjust an air flow by a suction valve. |
| 5 | Points to be checked during operation | <ul style="list-style-type: none"> ● After starting, check a pressure gauge to see if suction and discharge line pressure are correct and an air flow meter to see if the specified air flow is obtained. ● Keep a suction line pressure at or below atmospheric pressure. ● In case electric power has failed while the pump is running, switch off main power. Otherwise, the motor may not restart or may burn out depending on a line pressure at the time of power recovery. |

Operation

■ Stop and storage

- Before a long period of stop (1 week or more)...
Release pressure and remove liquid from the pump and then stop air/gas supply.
Some liquids may harden or crystallize when they are left for a long time. In this case clean wet ends before resuming operation.
- Do not store the pump in the following places where...
 1. Ambient temperature exceeds 40°C or falls below 0°C.
 2. Under a flammable/corrosive atmosphere or in a dusty/humid place.
 3. Under vibration or wind & rain.

Maintenance

1. Trouble shooting

Turn off power on sensing danger and check the following. In case trouble can not be solved, contact us or your nearest distributor.

| Phenomenon | | | | | Measures |
|--|-----------------------|-----------------------|-------------------------------------|-----------------------|--------------------------------------|
| Causes | Pump does not run. | Pump stops running. | Poor air flow or discharge pressure | Pump makes noise. | |
| No power distribution | <input type="radio"/> | <input type="radio"/> | <input type="radio"/> | <input type="radio"/> | Check wiring. |
| Motor trouble (disconnection or capacitor failure) | <input type="radio"/> | <input type="radio"/> | <input type="radio"/> | <input type="radio"/> | Replace the pump. |
| Wrong tubing or poor connection | <input type="radio"/> | <input type="radio"/> | <input type="radio"/> | <input type="radio"/> | Check and fix tubing. |
| Pump head mounting screws are loose. | <input type="radio"/> | <input type="radio"/> | <input type="radio"/> | <input type="radio"/> | Tighten the screws. |
| Diaphragm insertion is loose. | <input type="radio"/> | <input type="radio"/> | <input type="radio"/> | <input type="radio"/> | Tighten diaphragm. |
| Diaphragm is damaged. | <input type="radio"/> | <input type="radio"/> | <input type="radio"/> | <input type="radio"/> | Replace diaphragm.* |
| Filter is clogged. | <input type="radio"/> | <input type="radio"/> | <input type="radio"/> | <input type="radio"/> | Remove foreign matters. |
| Valves are worn. | <input type="radio"/> | <input type="radio"/> | <input type="radio"/> | <input type="radio"/> | Replace valves.* |
| Higher suction pressure than atmospheric | <input type="radio"/> | <input type="radio"/> | <input type="radio"/> | <input type="radio"/> | Reduce suction pressure. |
| Eccentric shaft has worn. | <input type="radio"/> | <input type="radio"/> | <input type="radio"/> | <input type="radio"/> | Replace the pump. |
| Connecting rod bearing has worn. | <input type="radio"/> | <input type="radio"/> | <input type="radio"/> | <input type="radio"/> | Replace the pump. |
| Motor bearing has worn. | <input type="radio"/> | <input type="radio"/> | <input type="radio"/> | <input type="radio"/> | Replace the pump. |
| Voltage reduction | <input type="radio"/> | <input type="radio"/> | <input type="radio"/> | <input type="radio"/> | Increase voltage to the rated level. |
| Front cover fixing screws are loose. | <input type="radio"/> | <input type="radio"/> | <input type="radio"/> | <input type="radio"/> | Secure them. |
| The pump head is filled with liquid. | <input type="radio"/> | <input type="radio"/> | <input type="radio"/> | <input type="radio"/> | Drain liquid. |

Contact us for the measures marked with *.

2. Maintenance & Inspection

■ Daily inspection

Pay attention to the following items during operation. Stop operation on sensing any danger and solve problems on the trouble shooting section. If pump performance has remarkably reduced, replace wear parts.

| No. | Check that... | Measure |
|-----|--|---|
| 1 | Pump operation is normal. | <ul style="list-style-type: none"> • Apply the correct voltage and amperage. • Adjust the discharge/suction pressure. |
| 2 | No noise or vibration problems. | <ul style="list-style-type: none"> • Unusual noise/vibration may occur when pump operation is not normal. |
| 3 | There is no air leak/suction from pump parts and tubing connections. | <ul style="list-style-type: none"> • Retighten connections. |

■ Pump replacement

Replace the pump at the end of life span or when performance has remarkably reduced.

| Model | Load | *Life span |
|------------------|----------------|------------|
| APN-30 APN-60 | All load range | 4000 hr |

* Life span is shown to get a rough idea. It is not guaranteed value. (The life span fluctuates on working condition.)

Pump durability varies according to the pressure, temperature and character of gas/liquid.

Values on the above table are from a test result of continuous operation at ambient temperature in the range of 10 and 40°C.

Maintenance

Handling of the pump, maintenance and inspection should be carried out within this instruction manual. Do not handle the pump beyond the descriptions in this manual. We are not responsible for personal injury or property damage due to nonobservance of this warning. Contact us or your nearest distributor as necessary.





IWAKI CO.,LTD. 6-6 Kanda-Sudacho 2-chome Chiyoda-ku Tokyo 101-8558 Japan
 TEL:(81)3 3254 2935 FAX:3 3252 8892(<http://www.iwakupumps.jp>)

()Country codes

| | | | | | | | |
|------------------|---|-----------------------|-------------------|--------------------|--|----------------------|---------------------|
| Australia | IWAKI Pumps Australia Pty. Ltd. | TEL:(61)2 9899 2411 | FAX:2 9899 2421 | Italy | IWAKI Italia S.R.L. | TEL:(39)02 990 3931 | FAX:02 990 42888 |
| Austria | IWAKI (Austria) GmbH | TEL:(43)2236 33469 | FAX:2236 33469 | Korea | IWAKI Korea Co.,Ltd. | TEL:(82)2 2630 4800 | FAX:2 2630 4801 |
| Belgium | IWAKI Belgium n.v. | TEL:(32)1367 0200 | FAX:1367 2030 | Malaysia | IWAKIm Sdn. Bhd. | TEL:(60)3 7803 8807 | FAX:3 7803 4800 |
| China | IWAKI Pumps (Shanghai) Co., Ltd. | TEL:(86)21 6272 7502 | FAX:21 6272 6929 | Norway | IWAKI Norge AS | TEL:(47)66 81 1660 | FAX:66 81 1661 |
| China | IWAKI Pumps (Guandong) Co., Ltd. | TEL:(86)750 3866228 | FAX:750 3866278 | Singapore | IWAKI Singapore Pte. Ltd. | TEL:(65)6316 2028 | FAX:6316 3221 |
| China | GFTZ IWAKI Engineering & Trading (Guangzhou) | TEL:(86)20 8435 0603 | FAX:20 8435 9181 | Spain | IWAKI Iberica Pumps, S.A. | TEL:(34)943 630030 | FAX:943 628799 |
| China | GFTZ IWAKI Engineering & Trading (Beijing) | TEL:(86)10 6442 7713 | FAX:10 6442 7712 | Sweden | IWAKI Sverige AB | TEL:(46)8 511 72900 | FAX:8 511 72922 |
| Denmark | IWAKI Nordic A/S | TEL:(45)48 24 2345 | FAX:48 24 2346 | Switzerland | IWAKI (Schweiz) AG | TEL:(41)26 674 9300 | FAX:26 674 9302 |
| Finland | IWAKI Suomi Oy | TEL:(358)9 2745810 | FAX:9 2742715 | Taiwan | IWAKI Pumps Taiwan Co., Ltd. | TEL:(886)2 8227 6900 | FAX:2 8227 6818 |
| France | IWAKI France S.A. | TEL:(33)1 69 63 33 70 | FAX:1 64 49 92 73 | Taiwan | IWAKI Pumps Taiwan (Hsin-chu) Co., Ltd. | TEL:(886)3 573 5797 | FAX:(886)3 573 5798 |
| Germany | IWAKI EUROPE GmbH | TEL:(49)2154 9254 0 | FAX:2154 9254 48 | Thailand | IWAKI (Thailand) Co.,Ltd. | TEL:(66)2 322 2471 | FAX:2 322 2477 |
| Holland | IWAKI EUROPE NL Branch | TEL:(31)547 293 160 | FAX:547 292 332 | U.K. | IWAKI Pumps (UK) LTD. | TEL:(44)1743 231363 | FAX:1743 366507 |
| Hong Kong | IWAKI Pumps Co., Ltd. | TEL:(852)2 607 1168 | FAX:2 607 1000 | U.S.A. | IWAKI AMERICA Inc. | TEL:(1)508 429 1440 | FAX:508 429 1386 |
| Indonesia | IWAKI Singapore (Indonesia Branch) | TEL:(62)21 690 6606 | FAX:21 690 6612 | Vietnam | IWAKI pumps Vietnam Co.,Ltd. | TEL:(84)613 933456 | FAX:613 933399 |